



PROP TORQUE

Official Newsletter of Launceston Model Aero Club Inc. PO Box 1204 Launceston TAS 7250

Volume 19, Issue 3

April 2010

From the President

Hello Everyone

Well, Autumn is here. Normally we'd expect lots of calm, pleasant days around this time, but it seems (at least to me) that this may not be happening. Nevertheless, we should make the most of the days we are given. More on that later.

As reported by Geoff in the Secretary's column, the mowing roster will be extended beyond the committee to include volunteers from club members. This is a good idea which I fully support, so if anyone is inclined to help, the committee would be pleased to hear from you and will find you a place in the saddle, so to speak.

LMAC will again be sending two delegates to the TMAA AGM to be held at Oatlands on Sunday 30 May. If anyone has any matter that they think should be represented to the TMAA, please discuss it with a committee member **before the next LMAC committee meeting, scheduled for 10 May**. The reason for this is that the TMAA meeting is not a general forum, and all such matters need to be ratified by your committee, beforehand.

As hinted at earlier, the inclement weather which we seem to be having more and more of these days, has prompted thinking about indoor flying. The committee has since endorsed a proposal by Greg Robertson for a winter season of indoor R/C competition, which may be pylon or aerobatics type

events. Greg is suggesting all participants have identical models with the same equipment (motor, ESC, battery, etc) so that events will reflect the flyers' skills and not their cheque books or credit cards. Venues have not yet been discussed. Whether this idea gains any traction will depend entirely on you, the members, showing your interest and making a commitment to participate. Based on the "show of hands", the committee will then look into a suitable venue, types of models and appropriate rules, etc. If you are interested, please contact Greg Robertson.

Finally, for those of you who admire wacky (or is that quacky) models, especially if made from alternative materials, you should take a look at <http://www.mudduckaviation.com/>. This the home page for the Mud Duck, a model that was around quite a while ago, but went off-line for a number of years. It has some terrific advantages claimed for it: it flies very slowly on low power and is good for rough fields. The new line of kits (plans also available) include one of 108-inch wing span, with a top speed of 15mph (24km/h) on a 91 four stroke! Who knows, we might see some 'Ducks at Symmons Plains next season!

I wish everyone good (and safe) flying (whether outdoors or indoors).

.....Gerry

From the Secretary's Desk

Hi All,
Another month rolls away into history with now only 2 months to go before the official start of winter.

Not a lot to report on again this month not even one birthday to send wishes to, so it must be one of those in between months, not like last month where we certainly had

INSIDE THIS ISSUE

1 From the President. From the Secretary,

2 Contest Directors report, Obituary David Boddington. From the Editor's desk

3

a flush of birthday greetings.

At our last committee meeting the matter of grass cutting at our flying site was raised. The committee has been doing this over this last year in teams of 2 for obvious safety reasons. Due to health reasons and other constraints this task has become a bit difficult as of late. It was decided that we would ask the membership if there may be some who could spare a couple of hours or so on a roster basis with a committee member on a Friday to help with this. There is more to cutting just the strip with the ride-on mower, because the hand mower is needed to cut around the Transmitter pound, along the fence line and around the tables. The areas around the clubhouse, under the shade cloth, around the toilets and machinery shed also need mowing. So you can see there is quite a bit to be done if it is to be done properly. If anyone could see this as a chance to help your club and members then please let me know so that I can make a roster up as soon as possible.

At the moment a 2 week roster will probably suffice, while during winter this would be less frequent. If we could get say 4 members to team with a committee member in teams of 2 it should spread the load out fairly well. Please let me know if this could be for you.

Something else for you to be thinking of is our Annual General Meeting which is scheduled for Thursday 10th of June 2010 at the Kings Meadows Health Centre 7.30 PM.

Committee members finishing their terms at this meeting will be our President Gerry DeGroot and 2 committee positions of Greg Robertson and Terry Pearson.

Well I think that is about all from me for this month But I would leave this thought with you all to ponder upon.

“ Believe it and you will achieve it”

So as always
Happy landings all,

Geoff.

Contest Director's Report

There were no contests to report on this month.

Chris Klimeck
Contest Director.

Obituary Notice

David Boddington 1932-2010

By David Ashby

The sad news has reached us that David Boddington passed away on 10th April after a long illness. He was 77.

The former RAF pilot, model designer, kit manufacturer, writer and magazine editor leaves a lasting legacy and will be greatly missed.

There's little that Boddo, as he was affectionately known, hadn't achieved throughout a prolific aeromodelling career. David was without 'side', always friendly, helpful and full of great stories.

To many a great friend, he was one of the hobby's true giants and will be greatly missed.

From the Editor's Desk

New Cheap 2.4 GHz equipment.

There have been other improvements in our access to new electronic equipment that I shall be mentioning this month. The first is a modular system suitable for JR and Futaba transmitters, first reviewed by Bob Hickman in Airborne number 230. In the latest Airborne, 231, he announced that the system called FlyDream is now approved by the MAAA for our use, having passed all the statutory tests, it is now therefore been included in MOP058. For those who may not have seen the review and the advertisement, it is sold by www.fly-rc.com.au for \$40.00 for the transmitter module and \$40.00 for the 8 channel receiver. (\$38.00 for 6 and \$36.00 for 4 channels!) Other agents are www.flyelectric.com.au and www.airstrike.com.au. It has a range checking facility and failsafe system on all the receivers. Bob Hickman is very happy with its use according to his latest report.

Magnetiser for screwdrivers.

Although a magnetised screwdriver can be quite irritating, Max Wiggins has sent me a picture below

of a tool for both magnetising and de-magnetising tools which he finds very helpful for tiny screw retrievals etc:



This is available from Robson Tool King, 124 Forster Street, Invermay, 7248.

Rose Bay, Sydney and flying boats.

Quite by coincidence, on a visit to Sydney to see one of my sons, he showed us the Beavers that he is now starting to fly in Rose Bay. I was unaware of these work horses and the fact that they have been used also for crop spraying and seeding. We were able to see them, as well as a Cessna, taking off and landing.

I have attached some images from the Beaver flight manual and a docked aircraft. Taxiing in and docking can be quite exciting apparently, with manipulation of the magnetos in order to reduce power as one approaches the jetty.



Ready to take on passengers, Rose Bay Jetty, Sydney.

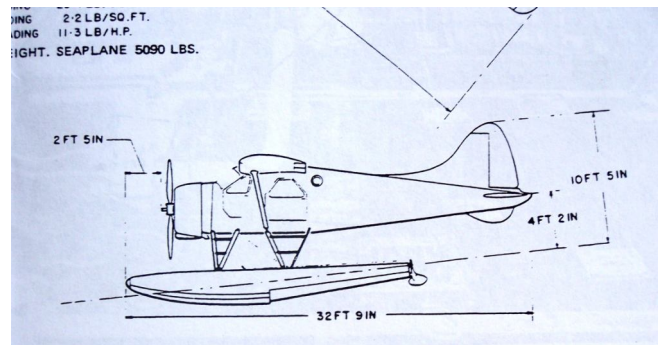
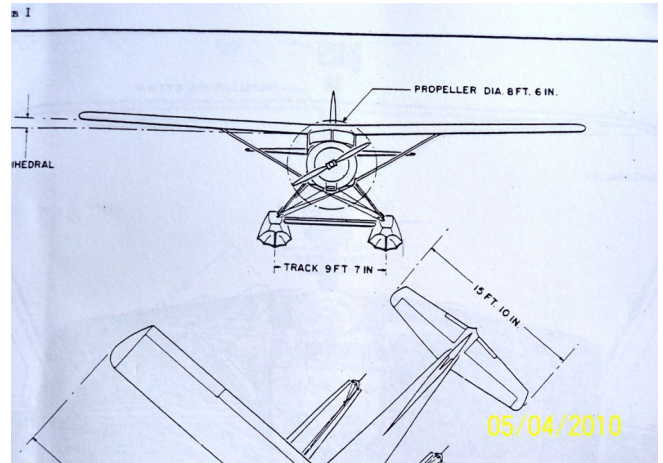
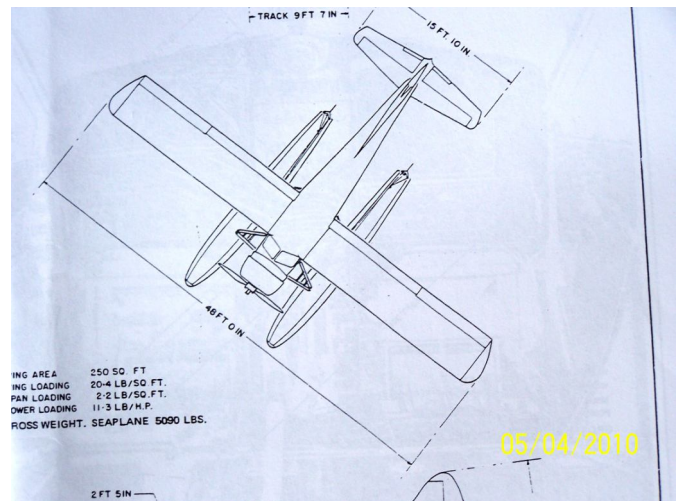

FIG 1-2 THREE VIEW DIMENSIONAL DIAGRAM - SEAPLANE

05/04/2010

Front and side views; De Havilland Canada Beaver Seaplane.



Plan View of DHC Beaver Seaplane.

(My apologies for the low standard of Photography)

Maiden Flight.

It was good to witness a successful maiden flight of Rob Laing's latest aircraft: a Spitfire Mk II by Hangar 9, with an ASP 90 four stroke motor installed. It certainly flies well!

...Richard..

EVENTS CALENDAR

Date	Events
May 1 st	Club Day
15 th	<u>Scale fly in</u>
June 5 th	Club Day
19 th	Old Timer/Tomboy event

Note: Starting times: - F/Flight----- 9 AM
 Old Timer-----11 AM
 All Other events except where noted----- 10 AM

This Calendar is subject to change that will be notified as required

Club AGM will be held Thursday June 10th 2010 venue TBA

CONTACTS

President	Gerry de Groot	6369 5284 / 0429 196 560	degroots@activ8.net.au
V.President	Kevin Hay	6326 2990 / 0417 011 839	zzkevin@skymesh.com.au
Secretary	Geoff Hays	6326 7967 / 0408 559 806	ghays7@bigpond.com
Treasurer/Webmaster	George Carnie	6398 2141 / 0418 134 672	george@thecarnies.ws
Committee	Greg A Robertson	63431753	
	Merv Cameron	6344 5614	mervcameron@internode.on.net
	Terry Pearson	0438 053 255	tnt13@bigpond.net.au
Editor	Richard Cooper	63695142	richardlc@activ8.net.au
Contest Director	Chris Klimeck	0458 448 674	cklimeck@bigpond.net.au
Web Site	www.lmacrc.com		