

# TOP TABLE

## JOE DI PRIMA DESCRIBES THE DESIGN AND BUILD OF CHARLIE MEYER'S ULTIMATE FIELD SAFETY ACCESSORY



the potential to close a field or even disband a club. Many US and UK groups have taken steps to deal with safety issues by appointing a member as a representative 'Safety Officer', and it is thus fella's job to report any safety violations, and suggest procedures for correction.

We have a Safety Officer in our club, and it is he who brought to our attention the number of

### BACKGROUND

Thriving, with a loyal 125 members, the Meroke R/C Club is based at Cedar Creek Aerodrome on Long Island, a site that issues 500 flying permits every year. As such, the aerodrome is a very busy place which has been in use since the mid 1970s, though due to budget constraints, Nassau County has not been able to provide many amenities for us modellers. We had a few old

Bench designer Charlie Meyer, starting a 40-size trainer.

It's increasingly important for all clubs who manage R/C model flying sites to insure they have safety measures in place which protect their interests - indeed, serious individual injuries can lead to lawsuits that have



Standard bench on the left, with a Birdie 10 ready for starting; Scale bench on the right, with a Piper Cub in readiness.

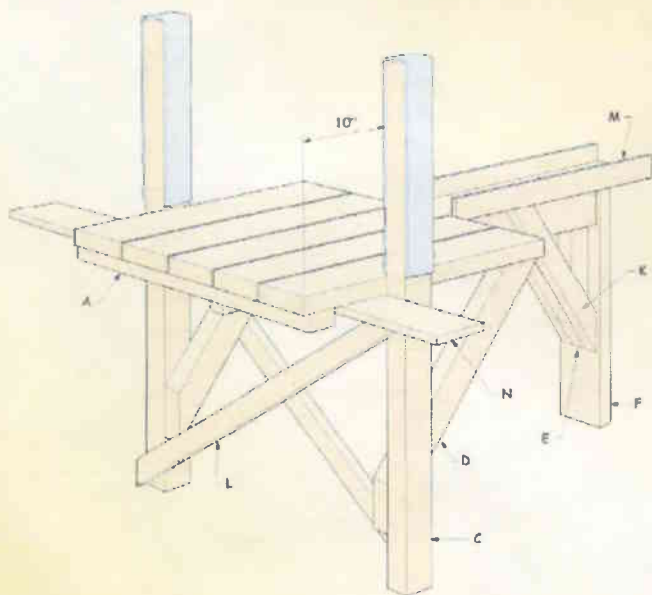

members who were incurring injuries to their fingers as a result of aeroplanes being inadequately restrained during the starting procedure. It was this fact that highlighted the need for a stable and safe field bench, and whilst the item you see here was designed specifically with this in mind, it is pleasing to report that the finished product has likewise proved to be user-friendly and convenient in other respects too.

broken picnic tables to rest our planes on, but not much else!

In 1999, club member Charlie Meyer and his brother Bob decided to form the volunteer group 'Friends of Cedar Creek Aerodrome', in order to make some improvements at the field. The team, which still functions, consists of both club members and non-members; it concerns itself primarily with safety.

Working with Nassau County Legislator, David Denenberg, the guys were able to obtain materials with a view to fabricating additional benches to hold our models. In practice, the old picnic table seats made it difficult to get near the aeroplanes, and several people had tripped with a running

engine while trying to move their model to the flightline.

After collecting donations from the fliers, Charlie designed and built a prototype bench which was given immediate approval by all who used it. Such was the success, we decided to build another five with some left-over wood from a member's garden deck. However, since we have two runways, six benches were not enough - we needed even more!

Thriving on anything that presents a challenge, the newly appointed 'building group' asked the Meroke R/C Club's Board of Directors to allocate \$150 to build an additional five and, seeing the huge benefits that this would offer, they agreed. With cash in hand our treasurer, Fred Abeles, suggested we try to get a discount from the local lumber supplier. A good idea that proved fruitful, because they were very happy to oblige; in fact, they went one better than that, and donated enough wood to build all five benches! Riding on what seemed to be a 'high', we immediately wrote to four other suppliers in the area and, surprise, surprise, received more donations of lumber - enough to build yet another five benches.

Such is their popularity, when the club members arrive at the field, the new benches are always grabbed first because the guys just love 'em! They're a convenient design, safe, easily built, and inexpensive, even if you have to pay for the wood!

Our club has a monthly fun-fly event, and we use just one Safety Bench as a starting station. All the contestants line up in order alongside the bench, and as each one is called, he rests his model against the retaining posts, and operates his transmitter while another of our specially-designated members starts the engine. This helps keep better order, and allows the contestant to mentally prepare himself for the flight.

When it comes to combat models, and others without landing gear, a removable box or milk crate - placed between the wing restraints - is ideal for supporting the fuselage. In order to facilitate timely starting when combat flying, each 'plane has its own bench - again, a system that works well.

#### DESIGN

As mentioned above, the design of this bench promotes safety.

With those strong 2 x 4 vertical wing restraints, the model cannot move forward, even with the engine at full throttle. Mind you, we don't recommend running in this condition without first walking around to the side of the bench and holding the aircraft as normal.

The bench also provides a place to put your transmitter, starter and glow starter battery; it keeps everything in its place and, crucially, away from that spinning prop. It also allows the pilot to stand behind the engine when making adjustments to the running, and he doesn't have to lean over the model in order to pick it up and carry it to the flightline.

Got a rough field? No problem! The three-legged design allows this bench to sit on uneven ground without rocking.

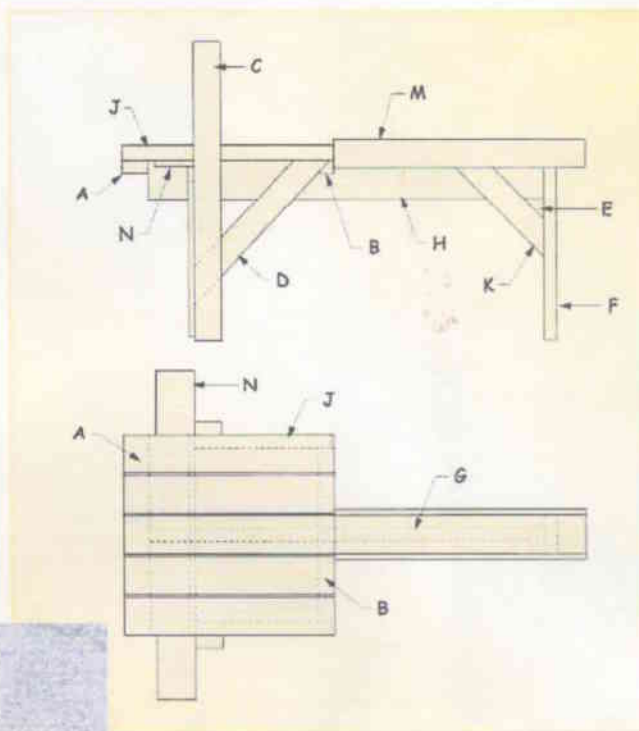

have to grovel on that damp, cold English turf whilst trying to start an engine! Trust me, you get a good, safe feeling when using this sturdy bench.

All wooden pieces needed for the 'Standard Safety Bench', in kit form.

#### BENCH CONFIGURATIONS

Two bench configurations are possible: the 'Standard', and the larger '1/4 Scale'. The first of these can hold a very wide variety of aircraft from .049 cu. in. engine size, right up to 1.6, and perhaps even larger. Some people have exceptionally big models of course, and for this Charlie has also designed the 1/4 Scale version. Here, a lower table keeps the spinner at the right height for starting, and makes the wing restraints longer for high-wing aircraft, such as a Piper Cub. Of course, the larger bench can be used for all the smaller aircraft, but do bear in mind you'll have to bend over further.

Whichever you decide to build, both use equal amounts of timber, and cost the same. In our experience, models that are larger and heavier than 1/4 scale are probably better handled on the ground.

#### MATERIAL LIST

All lumber was CCA Pressure-treated for durability. We purchased it in 8 foot lengths for handling convenience, but if you wish to minimize waste, you'd best buy the longest lengths possible.

Underside view of the table-top: A truly sturdy construction.

## TIMBER

Length (feet)	Size (inches)	Quantity
24	2 x 6	50 x 150
20	2 x 4	50 x 100
20	1 x 4	25 x 100
4	1 x 6	25 x 150

## HARDWARE

- 1/2 lb. No. 8 all weather deck screws 3" long
- 1/8 lb. No. 8 all weather deck screws 2" long
- T-50 staples

## OTHER

Scrap carpet, to act as a cushion on the wing restraints

## TOOLS REQUIRED

- Tape measure
- Hammer
- Wood chisel
- Carpenters framing square
- Pencils
- 7" circular saw
- 10" power mitre-saw

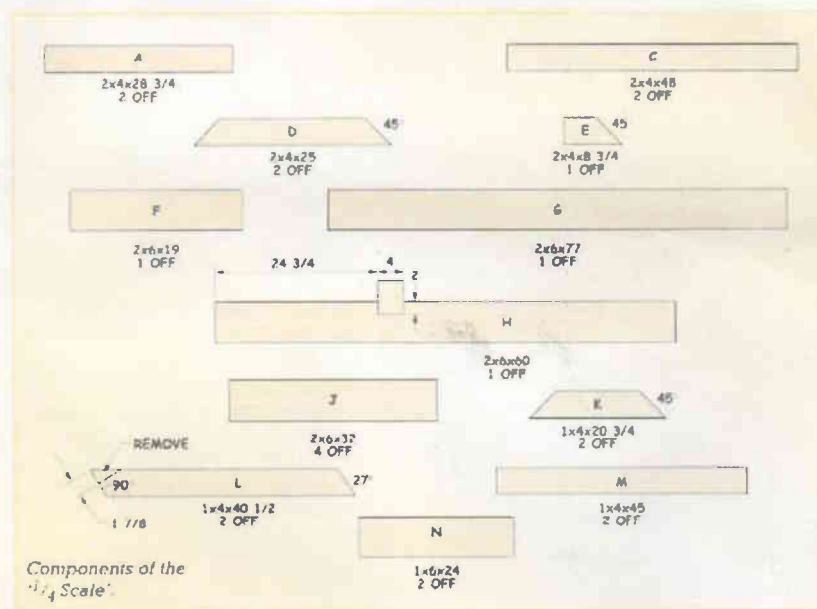
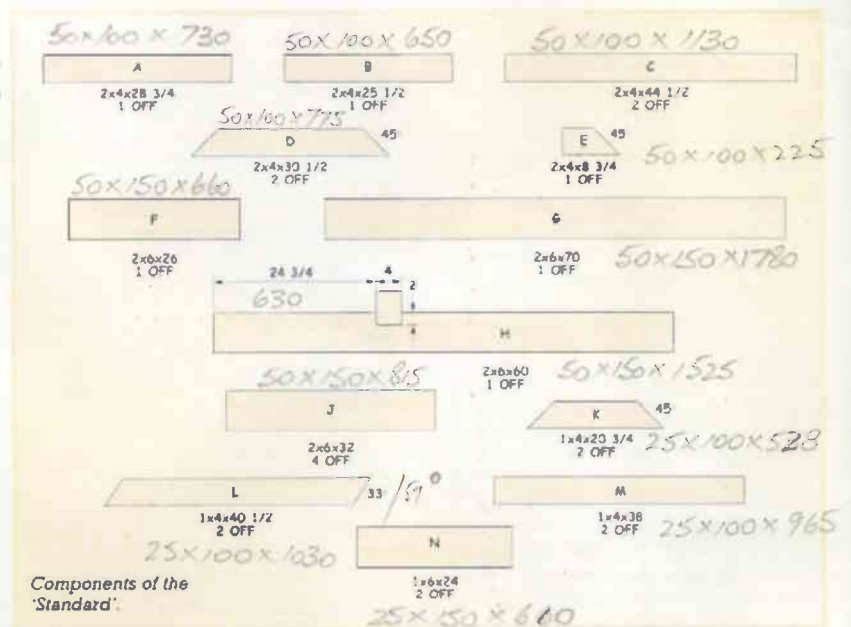

evenly, add a screw in each of the corners (from the top), square the whole thing up, then wind in the other screws using four in each plank (two each end).

With the table-top constructed, add the horizontal spine, centered under the long 2 x 6" middle plank. The spine must be notched where it meets the rear cross-brace, though said notch does not have to be very precise. If you like, it can be cut with a circular saw (several times) and then knocked out with a hammer. Of course, you can use a chisel if you prefer. Six evenly spaced screws are adequate to fasten the spine.

Draw two guidelines at 26 and 28" (from the bottom) across the inside face of both 2 x 4" front legs. Add the legs, using two screws for each, making sure to attach them 10" back from the upper front edge of the table-top, with the top centred between the guidelines. Turn the

- Electric drill
- 7/64" drill bit
- Electric screwdriver
- Extension cords
- T-50 staple gun
- Stanley knife

## ASSEMBLY - STANDARD BENCH

For speed, we built five benches at a time, and made templates of all the pieces for future use.

Start by assembling the top, pre-drilling all screw holes with a 7/64 bit to prevent the wood from splitting. Lay the 2 x 6 pieces over the pair of 2 x 4 cross-braces, noting that the rear cross-brace is inset the width of a 2 x 4 on each side. After spacing the top pieces



One of the building crews (L-R): Charlie Meyer, Joe Di Prima, Terry O'Grady, Tim Murphy, Bob Meyer, Hank Riehl, Sal Martella and John Dwyer.



*Note how everything has its place. The field box is hung on the right side extension, starter and glow igniter are on the table, and the transmitter can either be left on the table or placed on the left side extension.*

table upside-down, and add the 1 x 6 x 24" field box supports. These should be butted against the spine and the leg. Use at least seven screws on each support.

Time to fit the 2 x 4" angled side-braces. Once again, use two screws on each end, and make sure you 'square' the legs before finally fixing. Attach the 1 x 4" front angle braces, working on the outer ditto, screwing at the bottom, then squaring the front legs before fixing at the top. Repeat with the other brace.

Butt the rear leg against the spine end, fix with two screws, then add the 2 x 4" angle brace in the same manner, before fitting the 1 x 4" braces on each side. Turn the table right side up, and add three more screws through the middle top piece and into the rear leg, plus a further two screws into the 2 x 4" angled brace that was previously installed. Add the 1 x 4" topside rails, using a piece of scrap 1 x 4 as a height guide. Finally, staple scrap carpet to the wing restraints using 1/2" T-50 staples or 3/4" roofing nails.

#### ASSEMBLY - 1/4 SCALE

Frankly, there's little difference between this and the Standard unit, except that the table height is lowered by 7". Remember to make the rear leg 7" shorter, and note also that the centre table-top plank is 7" longer. Part B has been replaced with a 'double' of Part A in this version, though the drawings show only the 'Standard' rig.

#### VARIATIONS

To accommodate the front wheel on certain tricycle undercarriage configurations, i.e. models with swept-back wings, it is, of course, possible to extend the centre plank at the front. Likewise, if a larger table-top is needed on the 1/4 Scale bench to suit aeroplanes with a wide-track undercarriage, then additional lengths of 'Part J' can be added. Naturally, if this is done, the top cross-braces and the leg braces will have to be adjusted accordingly. It's all easily done though.

If you really want to go to town, wheels can be added to the front legs so that one person can move the table more easily - here again, if you make this modification, the rear leg will have to be extended to accommodate the difference, and keep the table level. Brackets can be added to the front of the wing restraints to hold your transmitters, if desired. At the end of the day, if you have a place for everything, it'll be a safer unit to use.

Feel free to contact us for more information if you need it. Good luck, and safe starting!

**Charlie Meyer (bench designer):** CMeyer2474@aol.com  
**Meroke Secretary Joe Di Prima:** joed111@optonline.net  
**Meroke R/C Club website:** <http://home.nyc.rr.com/merokerc>

# MULTIPLEX®

## The name for innovation -

# ROYAL EVO™



**Available  
now!**

## HIGH END- DIGITAL-RC-SYSTEM MADE IN GERMANY

Ask your specialized MULTIPLEX dealer  
for information!

MULTIPLEX Modelltechnik GmbH • Neuer Weg 15  
D-75223 Niefern • [www.multiplex-rc.de](http://www.multiplex-rc.de)