

FIELD SAFETY BENCH



- Safe airplane positioning due to sturdy wing restraints
- Super convenient.
- No more crawling around on the ground.
- Visible safety features of the bench encourage flyers to think about their actions.
- Safer than tail hooks.
- Inexpensive, see our text to see how we got contributions that paid for approximately 50% of the materials. Think about the great bench we got for the price of what we would pay for one replacement battery for a transmitter.
- No need for big heavy field boxes, just the small portable type is needed.
- Tune the engine from behind that spinning prop.
- A place for everything.
- Everything is at the right height .No bending over while starting or removing the airplane.
- 3 legged design means the bench will be steady on uneven ground.
- 3 Legged design allows you to get behind and next to the airplane, no reaching out.
- Compact design.
- Light enough for 2 flyers to carry easily.

- If wheels are fitted to the front legs they are very easy to move for grass cutting.
- Easy to build, particularly if you lay out the first bench and use the pieces as patterns.
- Standard size Safety Bench can handle a wide range of airplanes .049 to 1.6. In our experience.
- 1/4 Scale Safety Bench can handle all 1/4 scale and some 1/3 scale airplanes. When they get larger than the bench can handle, the airplane should be kept on the ground.
- 1/4 Scale Safety Bench can handle all the sizes of the Standard Bench but you have to bend over another 7 inches.
- Can be used for Fan Jets or other swept wing airplanes that have extended long nose wheels with a slight modification or just extending the center plank in the table during construction.



Do's and don'ts for building the Safety Bench

- Do try to get contributions to fund this project.
- Do consider building at least one of the larger 1/4 Scale bench for a trial they are very versatile. They can handle the big planes as well as all of the smaller planes.
- Do not change the lumber thicknesses .Weight on the tail end is desirable.
- Do not eliminate the central spine, part **H**. It is particularly important in a long run to keep the bench rigid and to keep it from going swayback in time.

- Do not shorten the benches in length .The extra length is good for leverage against the engine thrust at full throttle
- Do use the deck screws to fasten the bench together .Our benches that were built 4 years ago are as rigid as the day they were built. Do not use lag screws or bolts they are much more expensive and loosen in time .I do not have experience with a nail gun but I think it is wise to use the proven method with deck screws.
- Do not eliminate any of the cross bracing parts **L**. You may use a smaller lumber like 1X3 instead of 1X4s but do no eliminate them.
- Do not eliminate the 2X4 braces going from the table top to the front legs parts **D**.
- Do not eliminate the part **M**. This piece is to catch the tail wheel on a taildragger.It would be a problem if the airplane was accidentally pushed in the tail section and the back of the airplane fell off the tabletop. Particularly if the engine was running.
- Do not try to put in the screws without pre-drilling the prescribed pilot hole. The longer ones in particular are much harder without the pilot hole.
- Do not put the screws close to the edge on the thinner 1 inch pieces.

Do consider building enough benches for the maximum number of flyers at the field at any one time. In my fields case we have about 500 fliers with 5 flight stations and we have 25 benches.

Construction of the Safety Bench

Materials for each bench: Standard or 1/4 Scale.

All lumber was CCA Pressure treated for durability .We purchased it in 8' lengths for handling convenience but if you wish to minimize waste buy the longest lengths possible.

Quantity in 8 foot lengths	Size
3 pieces	2X6
2 1/2 pieces	2X4
2 1/4 pieces	1X4
1/2 piece	1X6

Hardware:

1/2 lb. #8 all weather deck screws 3" long
 1/8 lb. #8 all weather deck screws 2" long
 T-50 staples

Other

Scrap carpet to act as a cushion on the wing restraints.

Tools needed:

Tape Measure
 Hammer
 Wood Chisel
 Carpenters Framing square
 Pencils
 7 "Circular saw
 10" Power miter saw
 Electric drill
 7/64 drill bit
 Electric screw driver
 Extension cords
 T-50 Staple gun
 Utility knife

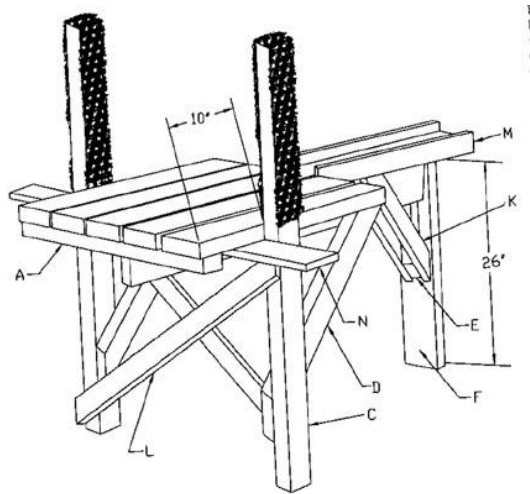

Assembly: for the "Standard Safety Bench "

We built five benches at a time and made templates of all the pieces to be used for building more benches in the future. The wood for all five benches was precut.

Pre-drill all screw holes with a 7/64 drill to prevent the wood from splitting.

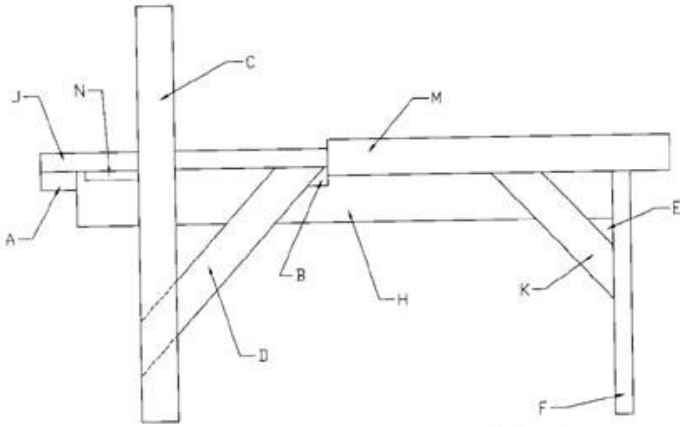

Start by laying 2 pieces of part **J** down. Lay down part **G** next to it. Lay down 2 more pieces of part **J** next to the part **G**. Make all pieces flush on one end and space each seam between the 5 boards with the thickness of the body of a deck screw. This will allow for swelling of the wood. On the flush end lay down flush on the front and flush on the ends the 2x4 part **A**. Use the big framing square and square everything up particularly on the front. Put in 2 screws on each top board. Next put down part **B** on the opposite end away from part **A**, note that the part **B** is shorter and should be the width of a 2x4 short on each side. again put 2 screws in each board.

After the top is constructed lift it up and turn it over, slip under the Spine which is part **H**. The horizontal spine must be centered under the middle of the long 2X6 top piece part **G**. The spine must be notched where it meets the rear cross brace part **B**. This notch does not have to be very precise. It can be cut with a circular saw and then knocked out with a hammer. Make several cuts before knocking it out. You can use a chisel if you prefer. Screw the spine to the Part **G** with about 8 screws.

The 2X4 front legs part **C** can be added now. Use two screws on each. Draw guide lines across both legs at 26" & 27 1/2". The legs are attached 10" back from the front of the top and with the top centered between the guidelines on the legs. Make sure the 26" length is toward the bottom. Turn the table upside down and add the field box supports part **N** on each underside. These should be butted against the spine and back against the leg. Use at least 7 screws on each support. The 2X4 angled side braces part **D** is added next with two screws on each end. Make sure to square the legs using the big framing square before screwing in the braces. The front 1X4-angled braces part **L** is now added. Screw in the bottom of the front one first then square the other leg left to right before screwing in the top screws. Repeat with the other brace. It is important to square everything before screwing in the bracing.

The rear leg part **F** is attached by butting it against the spine end. Use two screws into the spine. Add the short

2X4 angled brace part **E** in the same manner. Attach the 1X4 small-angled braces part **K** on each side.

Turn the table right side up. Add three more screws through the middle top piece part **G** into the rear leg and two screws on each rear corner of the top into the 2X4 angled brace part **D** that was previously installed. Attach the 1X4 topside rails part **M** on both sides. Use a piece of scrap 1X4 as a height guide to make the topside rail approximately 1 inch higher than the part **G**.

To prevent abrasion between the 2x4 wing restraints and the airplane wings we used surplus or used carpet to act as a cushion. Add scrap carpet to the airplane wing restraints using 1/2", T-50 staples or 3/4" roofing nails.

Assembly for the "1/4 Scale Safety Bench"

The assembly of the 1/4 Scale Safety Bench is essentially the same except the table height is lowered by 7 inches. The rear leg will be 7 inches shorter and the length of the main top piece will therefore be 7 inches longer. Notice there are 2 cross braces part A and no part B. The longer part A's are used in both positions for the Part A and Part B on isometric drawings as well as the side and top view drawings.

Variations:

- The center board piece "G" can be extended out in front to accommodate the front wheel on tricycle landing gear for planes with swept back wings such as Fan Jets.
- For the 1/4 Scale Safety Bench, if a wider top is needed to accommodate wider landing gear, additional top pieces Part **J** can be added, they do not have to be full width 6 inches wide but rather can be 2 or 4 inches wide on either side. Naturally if this is done the top cross braces and the leg braces will have to be adjusted accordingly.
- Wheels can be added to the front legs so that one person can move the table more easily. If wheels are added, the rear leg will have to be extended to make up the difference of the wheel height.
- Brackets can be added to the front of the wing restraints to hold the transmitters.
- Hooks can be added to the front edge of the bench or the box supports to hang a transmitter.

- Holes can be drilled in the bench top to have a definite place to put the neck of the glow starter in each time you are finished with it. A place for everything makes it safer.

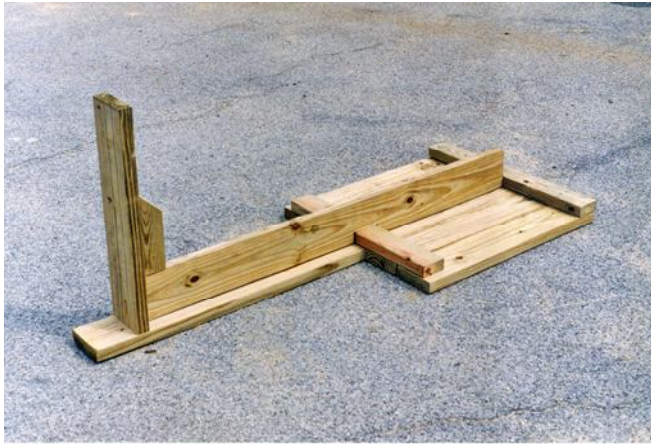

Material cut list



You will recognize this as a "KIT"

STANDARD SAFETY BENCH DIMENSIONS IN INCHES

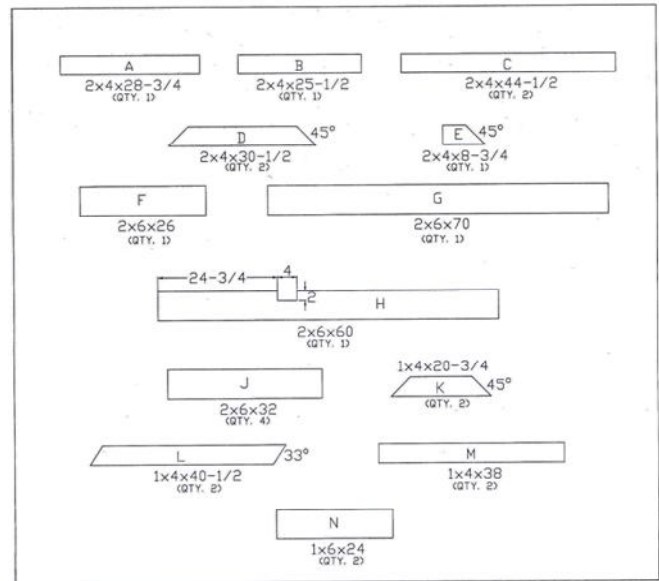

1/4 SCALE SAFETY BENCH DIMENSIONS IN INCHES

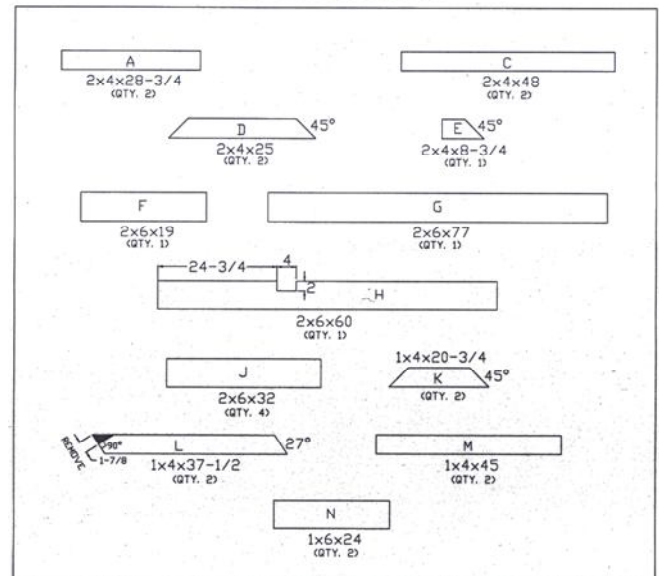

For further information contact the designer Charlie Meyer at CMeyer2474@aol.com mark all e-mails Subject : Safety Bench.

Property Meroke RC Club www.Meroke.com . AMA Charter club status # 458

When you have completed your Safety Benches we hope you will take a few pictures and send them to Charlie Meyer so he can add them to the Meroke RC Club scrapbook.